

# Q150 DATA SHEET

## General Dewatering



### PUMP SPECIFICATIONS

<b>Model</b>	Q150
<b>Suction Flange</b>	150mm - BS10 TableD
<b>Discharge Flange</b>	150mm - BS10 TableD
<b>Max Flow</b>	330m3/hr
<b>Max Head</b>	27m
<b>Solids Handling</b>	65mm x 80mm long
<b>Impeller Type</b>	Semi-Open 2 Vane Spiral (Ø230)
<b>Max Speed</b>	2050rpm

### MATERIALS OF CONSTRUCTION

<b>Pump Casing</b>	Cast Iron
<b>Impeller</b>	Stainless Steel
<b>Front Wear Plate</b>	Stainless Steel
<b>Rear Wear Plate</b>	Stainless Steel
<b>Shaft</b>	Stainless Steel
<b>Mechanical Seal</b>	Silicon Carbide/Silicon Carbide/Viton

### PRIMING SYSTEM

<b>System Type</b>	Vacuum Pump
<b>Air Handling Capacity</b>	110m3/hr(65cfm)
<b>Vacuum Max</b>	9m
<b>Priming Control</b>	Capacitance Probe
<b>Discharge NRV</b>	Rubber Flapper

### CONTROL

<b>Type</b>	DSE E100
<b>Autostart</b>	Floats or Level Sensor <i>(*as optional extra)</i>
<b>SMS Telemetry</b>	DSE890 <i>(*as optional extra)</i>
<b>Speed Control</b>	Mechanical

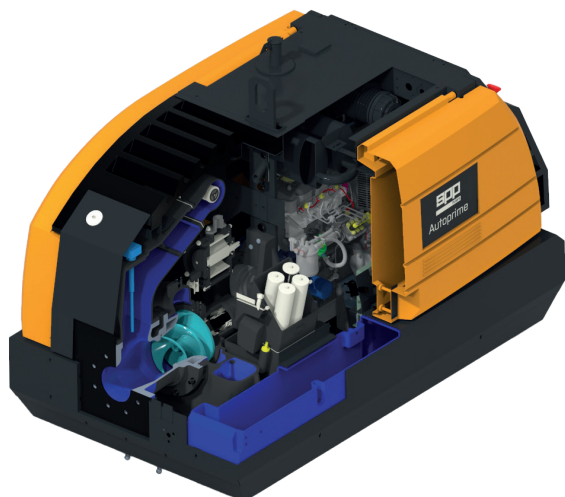

### PACKAGE SPECIFICATION

<b>Type</b>	Gull Wing Door
<b>Chassis Finish</b>	Powder Coat – RAL7021
<b>Canopy Door/Fuel Tanks</b>	Rotationally Moulded Polyethylene
<b>Fuel Tank Capacity</b>	220ltrs
<b>Sound Power Level</b>	97LWA
<b>Sound Pressure Level @7m</b>	70dB (A)
<b>Sound Pressure Level @10m</b>	67dB (A)
<b>Stackable</b>	N/A

*\*Optional door colour to suit customer branding*

### BAUER OPTIONS

150mm Suction/Delivery Bauer = 30kg/450mm Long Max

### ENGINE SPECIFICATION

<b>Engine Type</b>	Perkins 403J-17
<b>Max Power</b>	18.9kW@2800rpm
<b>Emissions Compliance</b>	EU StageV
<b>After Treatment</b>	N/A
<b>Speed Range</b>	1500 – 2050rpm
<b>Fuel Consumption @ BEP</b>	4.1l/h@2050rpm
<b>Max Running Hours @ BEP</b>	54hrs@2050rpm
<b>Rated Power @ BEP</b>	14.4kW@2050rpm

*\*Electric motor option available - with optional Soft Start/VSD Panels*



# Q150 DATA SHEET

## General Dewatering



# SPP

PUMPS

PROTECTING LIFE. IMPROVING LIVES.

### MOUNTING OPTIONS

Dimensions and weights below are excluding bauer/pipe connections.

Type	Dimensions LxWxH	Gross Weight (including fuel)	Complete with...	Alternative Hitch Options
POD	2103 x 1150 x 1350mm <i>*QPOD Shipping Pallet - 2200 x 1170mm - 65kg</i>	1225kg		
Fixed height road trailer - single axle	3506 x 1618 x 1850mm	1500kg	13pin lighting board, 2 x rear jack stands, step plate, 40mm towing eye	50mm Ball hitch, 75mm Nato hitch
Variable height road trailer - single axle	3970 x 1600 x 1778mm	1400kg	13pin lighting board, rear jack stand, 40mm towing eye	50mm Ball hitch
Skid base	2400 x 1180 x 1600mm	1380kg	Fork truck pockets, drag points	



### OPTIONAL EXTRAS

- Auto start/stop - float or level sensor
- Pump telemetry/remote monitoring
- Fuel valve for auxiliary fuel tank/cube
- Spark arrestor and chawyn valve
- DWI Reg31 (4) compliant pump options for potable water applications
- Emergency trailer with pipe and fittings
- Flashing beacon
- Battery isolator
- 2 x LED work lights
- Hose/pipework
- Spares kits
- Service and maintenance package
- Product training

# Q150 DATA SHEET

## General Dewatering



### MULTI-SPEED PERFORMANCE CURVE

