

Q150S DATA SHEET

Solids Handling



PUMP SPECIFICATIONS

Model	Q150S
Suction Flange	150mm - BS10 TableD
Discharge Flange	150mm - BS10 TableD
Max Flow	310m ³ /hr
Max Head	28m
Solids Handling	90mm x 90mm long
Impeller Type	Semi-Open Single Vane Spiral (Ø228)
Max Speed	1900rpm

MATERIALS OF CONSTRUCTION

Pump Casing	Cast Iron
Impeller	SG Iron
Front Wear Plate	Cast Iron
Rear Wear Plate	Stainless Steel
Shaft	Stainless Steel
Mechanical Seal	Silicon Carbide/Silicon Carbide/Viton

PRIMING SYSTEM

System Type	Vacuum Pump
Air Handling Capacity	110m ³ /hr(65cfm)
Vacuum Max	9m
Priming Control	Capacitance Probe
Discharge NRV	Rubber Flapper

CONTROL

Type	DSE E100
Autostart	Floats or Level Sensor (*as optional extra)
SMS Telemetry	DSE890 (*as optional extra)
Speed Control	Mechanical

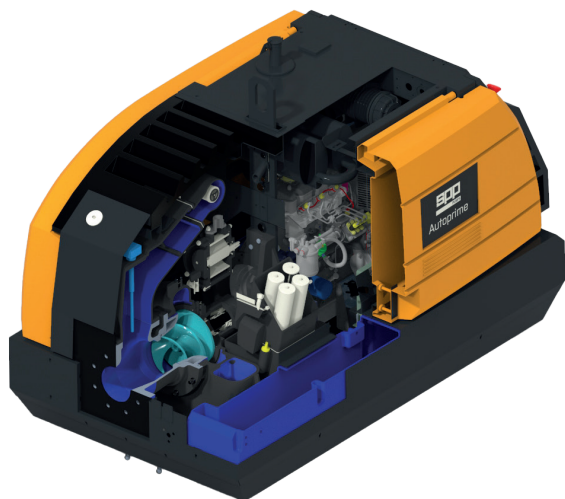

PACKAGE SPECIFICATION

Type	Gull Wing Door
Chassis Finish	Powder Coat – RAL7021
Canopy Door/Fuel Tanks	Rotationally Moulded Polyethylene
Fuel Tank Capacity	220ltrs
Sound Power Level	97LWA
Sound Pressure Level @7m	70dB (A)
Sound Pressure Level @10m	67dB (A)
Stackable	N/A

**Optional door colour to suit customer branding*

BAUER OPTIONS

150mm Suction/Delivery Bauer = 30kg/450mm Long Max

ENGINE SPECIFICATION

Engine Type	Perkins 403J-17
Max Power	18.9kW@2800rpm
Emissions Compliance	EU StageV
After Treatment	N/A
Speed Range	1500 – 2050rpm
Fuel Consumption @ BEP	3.5l/h@1900rpm
Max Running Hours @ BEP	63hrs@1900rpm
Rated Power @ BEP	12.3kW@1900rpm

**Electric motor option available - with optional Soft Start/VSD Panels*

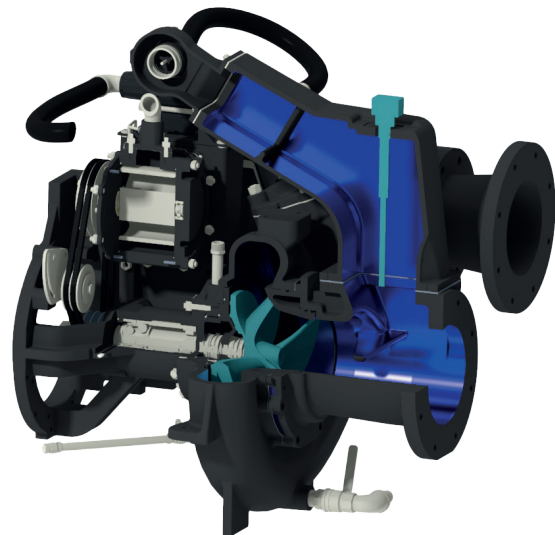

Q150S DATA SHEET

Solids Handling



SPP

PUMPS

PROTECTING LIFE. IMPROVING LIVES.

MOUNTING OPTIONS

Dimensions and weights below are excluding bauer/pipe connections.

Type	Dimensions LxWxH	Gross Weight (including fuel)	Complete with...	Alternative Hitch Options
POD	2103 x 1150 x 1350mm <i>*QPOD Shipping Pallet - 2200 x 1170mm - 65kg</i>	1225kg		
Fixed height road trailer - single axle	3506 x 1618 x 1850mm	1500kg	13pin lighting board, 2 x rear jack stands, step plate, 40mm towing eye	50mm Ball hitch, 75mm Nato hitch
Variable height road trailer - single axle	3970 x 1600 x 1778mm	1400kg	13pin lighting board, rear jack stand, 40mm towing eye	50mm Ball hitch
Skid base	2400 x 1180 x 1600mm	1380kg	Fork truck pockets, drag points	



OPTIONAL EXTRAS

- Auto start/stop - float or level sensor
- Pump telemetry/remote monitoring
- Fuel valve for auxiliary fuel tank/cube
- Spark arrestor and chawyn valve
- DWI Reg31 (4) compliant pump options for potable water applications
- Emergency trailer with pipe and fittings
- Flashing beacon
- Battery isolator
- 2 x LED work lights
- Hose/pipework
- Spares kits
- Service and maintenance package
- Product training

Q150S DATA SHEET

Solids Handling



MULTI-SPEED PERFORMANCE CURVE

