

DEWATERING HYDRAFLOW DATA SHEET

S2TC-2 50MM HYDRAULIC SUBMERSIBLE PUMP

The SPP HYDRAFLOW S2TC-2 Hydraulic Drive Submersible Pump is a very portable and versatile all purpose utility pump. An efficient channel impeller handles solids and offers excellent overall performance. This pump is available with either water or solids handling strainers.

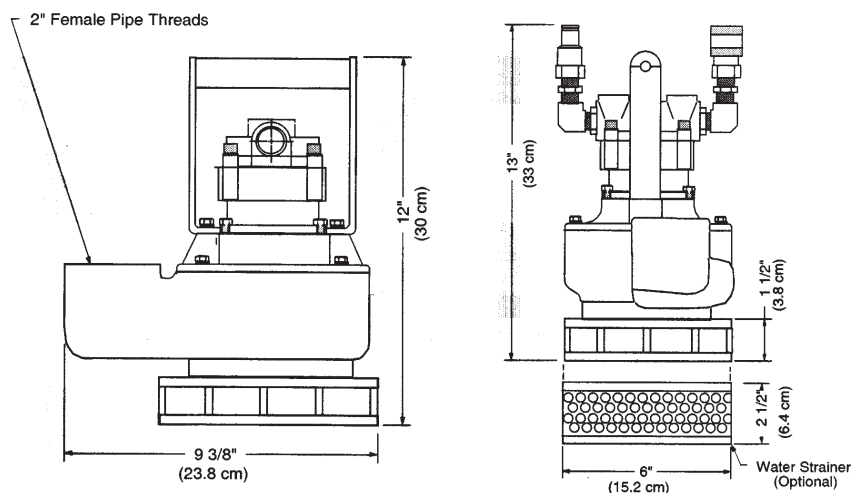

DESIGN FEATURES

- Efficient two channel impeller will pass 25mm semi solids.
- Rugged and reliable gerotor motor.
- Variable Speed Hydraulic Drive.
- Can be bolted into a pipeline or staged.
- Available with Ductile Iron, Aluminium or Stainless Steel casing.
- Safe Hydraulic Drive can be used where electric power is hazardous or impractical.
- Operates with our HT6, HT7DXR or HT11D Hydraulic Power Units or any open centre power source with output flows to 19 l/m.

DEWATERING

HYDRAFLOW DATA SHEET

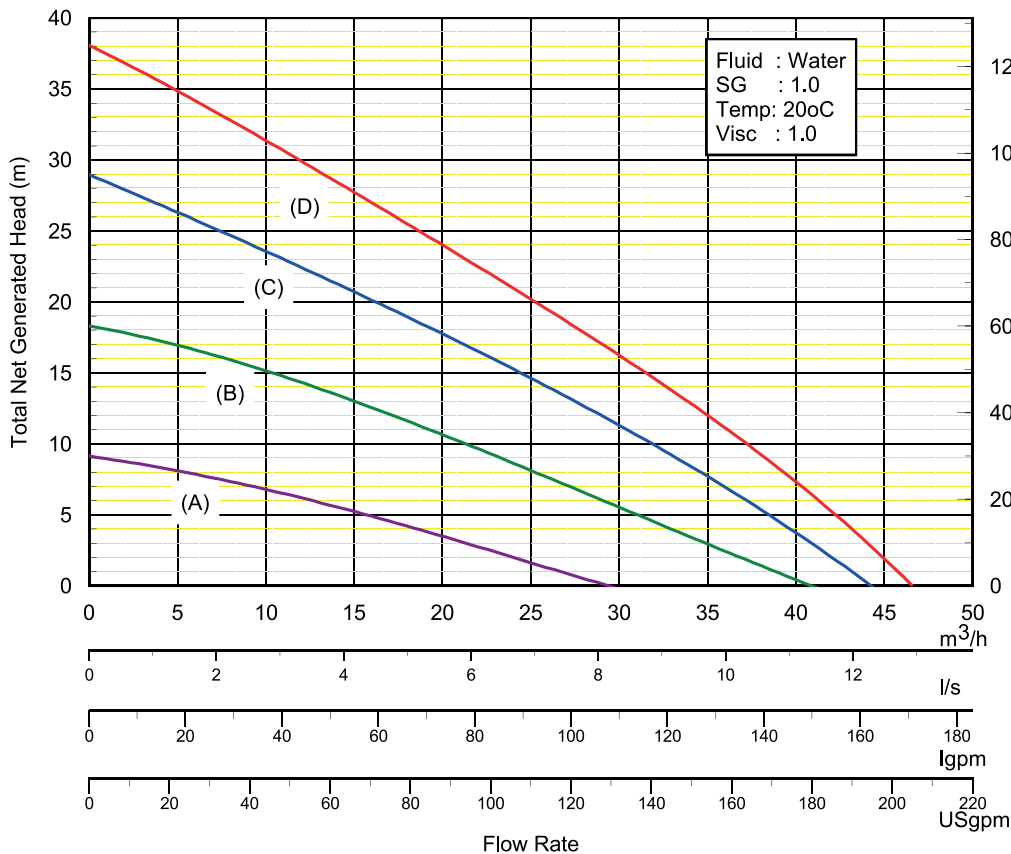

Hydraulic Input: (A) 8 l/m @ 76 bar (B) * 11 l/m @ 120 bar
(C) 15 l/m @ 151 bar (D) ** 19 l/m @ 172 bar Intermittent
* Typical performance with HT6D
** Typical performance with HT11D

HYDRAULIC SUBMERSIBLE PUMP

PUMP TYPE	S2TC-2
BRANCH SIZES	Suction: 50mm x Disch: 50mm
IMPELLER	Channel
SOLIDS HANDLING	25 mm dia
HYDRAULIC MOTOR	Gear
INPUT - HYDRAULIC FLOW	19 l/m
INPUT - HYDRAULIC PRESSURE	172bar
HYDRAULIC OIL	ISO 46
HYDRAULIC OIL TEMPERATURE	Max 140°F

PUMP SPECIFICATIONS

FLOW RATE	46 m³/h Maximum
DISCHARGE HEAD	38 m Maximum
WEIGHT	DI - 11kg or AL - 7.7 kg
HEIGHT	330 mm
MAX DIAMETER	238 mm
MAX SOLIDS SIZE	25 mm Diameter
HOSE PORT	3/8" SAE (O Ring)
SUCTION FLANGE	1 1/2" 125# Flange
DISCHARGE PORT	2" NPT F
POWER SOURCE	HT6, HT7DXR or HT11D
PUMP CASING	Ductile Iron or Aluminium
IMPELLER	Ductile Iron
WEAR RING &/OR PLATE	n/a
SHAFT	Heat Treated Steel Alloy
SHAFT SEAL - STANDARD	Carbon Ceramic
ALTERNATIVE SEAL	Refer to SPP
ELASTOMERS - STANDARD	Buna (N)
HYDRAULIC OIL	214-320 s.s.u. @ 64 Deg. C
INPUT FLOW	19 l/m Maximum
OPERATING PRESSURE	172 bar Maximum