

# DEWATERING

## HYDRAFLOW DATA SHEET

### S3TC 75MM HYDRAULIC SUBMERSIBLE UTILITY PUMP

The SPP HYDRAFLOW S3TC Hydraulic Drive Submersible Pump is a very portable and versatile utility pump designed for pumping jobs such as construction sites and manhole pumping. An efficient channel impeller offers excellent overall performance. This pump is offered in your choice of stainless steel, aluminum or ductile iron body.

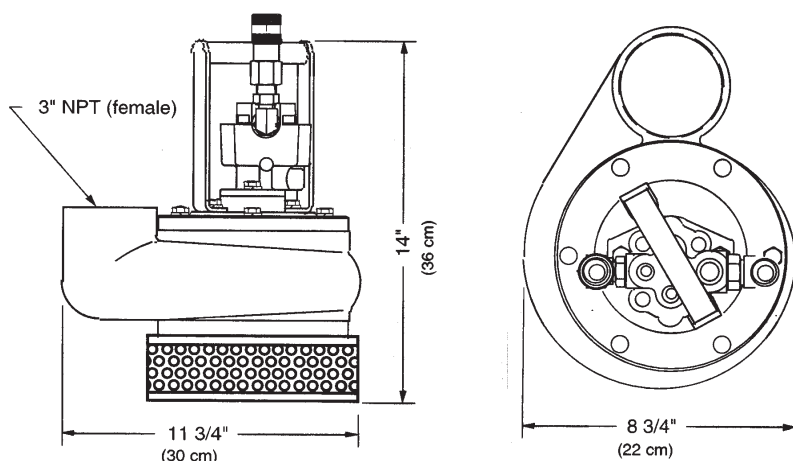

### DESIGN FEATURES

- Small overall size allows for use in very tight spaces.
- Efficient 2 vane channel impeller.
- Oil Lubricated Seals - pump can run dry.
- Dependable gear type hydraulic motor with variable speed.
- Available with Ductile Iron, Aluminium or Stainless Steel casing.
- Can be bolted to standard pipe flange and used as an in-line booster pump.
- Safe Hydraulic Drive can be used where electric power is hazardous or impractical.
- Operates with our HT11D, HT25D, HT35D or HSQ35D Hydraulic Power Units or any open centre power source with output flows to 30 l/m.

# DEWATERING

## HYDRAFLOW DATA SHEET

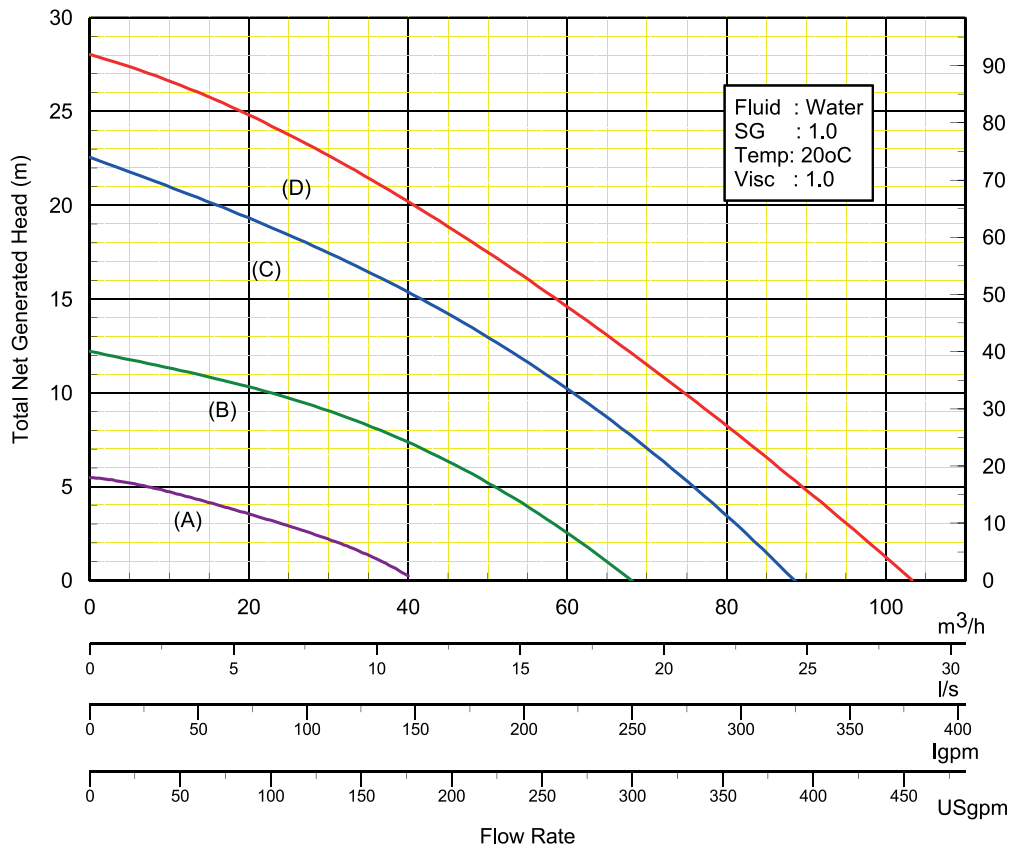

Hydraulic Input: (A) 11 l/m @ 34 bar (B) 19 l/m @ 72 bar  
(C) \* 26 l/m @ 145 bar (D) 30 l/m @ 172 bar  
\* Typical performance with HT25D

### HYDRAULIC SUBMERSIBLE PUMP

PUMP TYPE	S3TC
BRANCH SIZES	Suction: 75mm x Disch: 75mm
IMPELLER	Channel
SOLIDS HANDLING	20 mm diameter
HYDRAULIC MOTOR	Gear
INPUT - HYDRAULIC FLOW	30 l/m
INPUT - HYDRAULIC PRESSURE	172 bar
HYDRAULIC OIL	ISO 46
HYDRAULIC OIL TEMPERATURE	Max 140°F

### PUMP SPECIFICATIONS

<b>FLOW RATE</b>
103 m³/h Maximum
<b>DISCHARGE HEAD</b>
28 m Maximum
<b>WEIGHT</b>
DI - 24kg or AL - 13 kg
<b>HEIGHT</b>
360 mm
<b>MAX DIAMETER</b>
300 mm
<b>MAX SOLIDS SIZE</b>
20 mm Diameter
<b>HOSE PORT</b>
1/2" NPT F
<b>SUCTION FLANGE</b>
3" 125# ASA
<b>DISCHARGE PORT</b>
3" NPT F
<b>POWER SOURCE</b>
HT11D, HT25D, HT35D or HSQ35D
<b>PUMP CASING</b>
D Iron, Aluminium or St St
<b>IMPELLER</b>
Stainless Steel
<b>WEAR RING &amp;/OR PLATE</b>
Ductile Iron
<b>SHAFT</b>
Plated 4140 Stee
<b>SHAFT SEAL - STANDARD</b>
Carbon Ceramic
<b>ALTERNATIVE SEAL</b>
Refer to SPP
<b>ELASTOMERS - STANDARD</b>
Buna (N)
<b>HYDRAULIC OIL</b>
214-320 s.s.u. @ 64 Deg. C
<b>INPUT FLOW</b>
30 l/m Maximum
<b>OPERATING PRESSURE</b>
172 bar Maximum