

DEWATERING HYDRAFLOW DATA SHEET

S6150 150MM HYDRAULIC SUBMERSIBLE SOLIDS HANDLING PUMP

The SPP HYDRAFLOW S6150 High Performance, Hydraulic Drive Submersible Pump is a highly efficient solids handling pump used on jobs such as waste lagoons, barge transfer, sewer bypass and treatment plant duties. A guide rail system is available for installation in sewage lift stations or tanks.

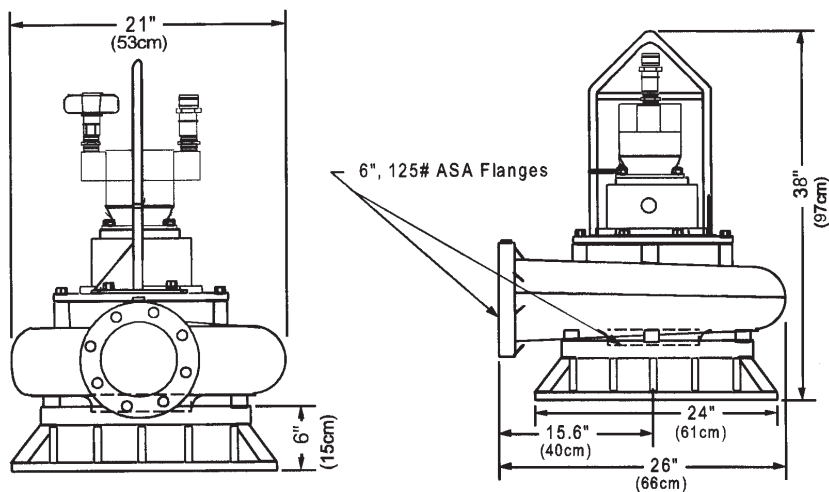

DESIGN FEATURES

- Balanced two vane closed channel impeller
- Oil lubricated silicon carbide seals - pump can run dry
- Variable Speed Hydraulic Drive
- Will pass 75mm semi solids
- Wide range of performance
- Available in stainless steel
- Safe Hydraulic Drive can be used where electric power is hazardous or impractical
- Operates with our HT100D, HT150D or HT200D Hydraulic Power Units or any open centre power source with output flows to 340 l/m

DEWATERING

HYDRAFLOW DATA SHEET

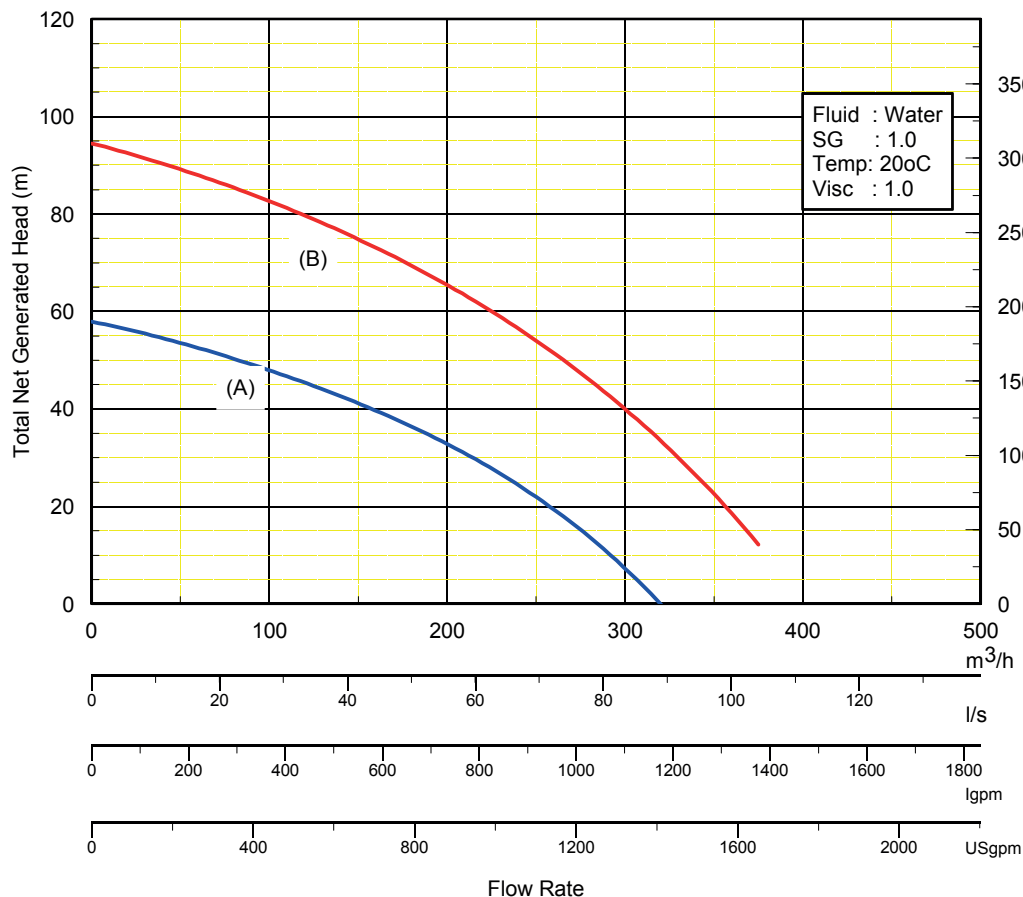

Hydraulic Performance with: (A) 189 l/m @ 172 bar
(B) * 265 l/m @ 172 bar
* Typical Performance with HT150D

HYDRAULIC SUBMERSIBLE PUMP

PUMP TYPE	S6150
BRANCH SIZES	Suction: 150mm x Disch: 150mm
IMPELLER	Channel
SOLIDS HANDLING	75 mm diameter
HYDRAULIC MOTOR	Gear
INPUT - HYDRAULIC FLOW	340 l/m
INPUT - HYDRAULIC PRESSURE	172 bar
HYDRAULIC OIL	ISO 46
HYDRAULIC OIL TEMPERATURE	Max 140°F

PUMP SPECIFICATIONS

FLOW RATE	540 m³/h Maximum
DISCHARGE HEAD	87 m Maximum
WEIGHT	294 kg
HEIGHT	970 mm
MAX DIAMETER	660 mm
MAX SOLIDS SIZE	75 mm Diameter
HOSE PORT	1 1/2" NPT
SUCTION FLANGE	6" 125# Flange
DISCHARGE PORT	6" 125# Flange
POWER SOURCE	HT100D, HT150D or HT200D
PUMP CASING	Cast Iron/Stainless Steel
IMPELLER	Ductile Iron
WEAR RING &/OR PLATE	n/a
SHAFT	17-4 PH Stainless Steel
SHAFT SEAL - STANDARD	Silicon Carbide
ALTERNATIVE SEAL	Refer to SPP
ELASTOMERS - STANDARD	Buna (N)
HYDRAULIC OIL	214-320 s.s.u. @ 64 Deg. C
INPUT FLOW	26 l/m Maximum
OPERATING PRESSURE	138 bar Maximum