

DEWATERING HYDRAFLOW DATA SHEET

S6300 300MM HYDRAULIC SUBMERSIBLE SOLIDS HANDLING PUMP

The SPP HYDRAFLOW S6300 High Performance, Hydraulic Drive Submersible Pump is a solids handling effluent pump used on jobs such as waste treatment, barge transfer and sewer by-pass duties. A guide rail system is available for installation in sewage lift stations or tanks.

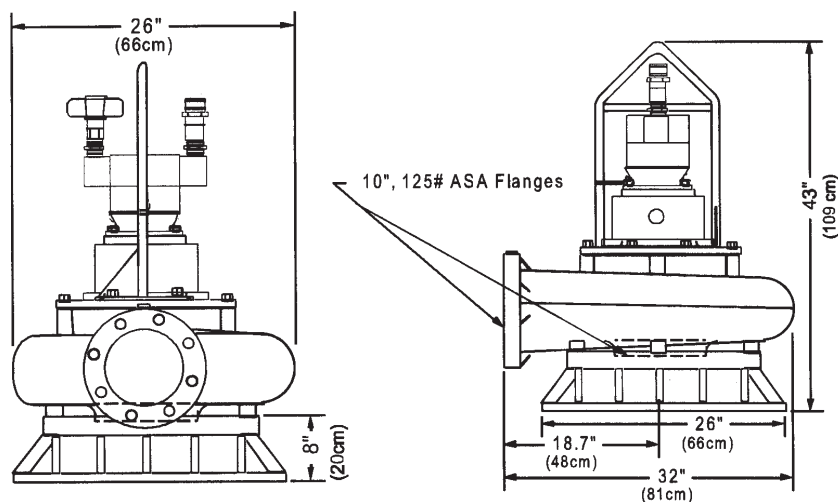

DESIGN FEATURES

- Balanced two vane closed channel impeller
- Oil lubricated silicon carbide seals - pump can run dry
- Variable Speed Hydraulic Drive
- Will pass 125mm semi solids
- Wide range of performance
- Available in stainless steel
- Safe Hydraulic Drive can be used where electric power is hazardous or impractical
- Operates with our HT100D, HT150D or HT200D Hydraulic Power Units or any open centre power source with output flows to 265 l/m

DEWATERING

HYDRAFLOW DATA SHEET

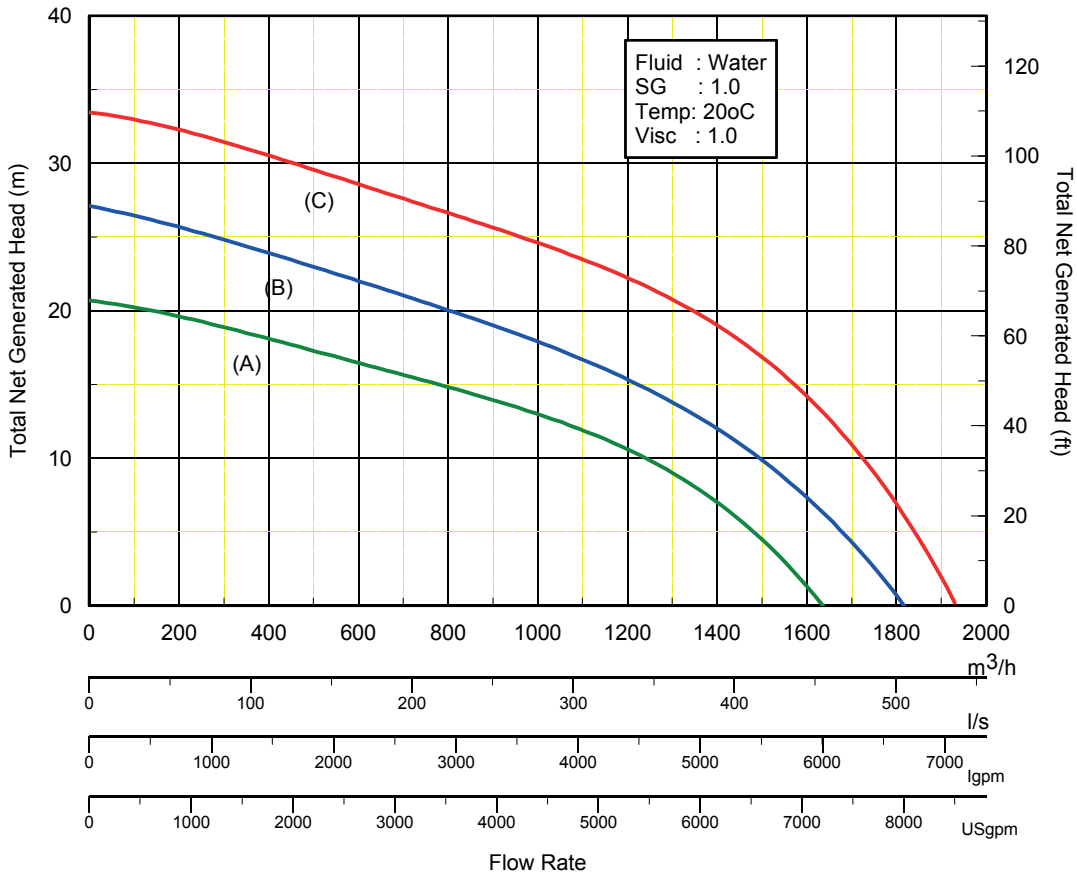

Hydraulic Performance with: (A) * Typical HT100D
(B) ** Typical HT150D
(C) *** Typical HT200D

HYDRAULIC SUBMERSIBLE PUMP

PUMP TYPE	S6300
BRANCH SIZES	Suction: 300mm x Disch: 300mm
IMPELLER	Channel
SOLIDS HANDLING	125 mm diameter
HYDRAULIC MOTOR	Gear
INPUT - HYDRAULIC FLOW	340 l/m
INPUT - HYDRAULIC PRESSURE	172 bar
HYDRAULIC OIL	ISO 46
HYDRAULIC OIL TEMPERATURE	Max 140°F

PUMP SPECIFICATIONS

FLOW RATE	1705 m³/h Maximum
DISCHARGE HEAD	43 m Maximum
WEIGHT	462 kg
HEIGHT	1140 mm
MAX DIAMETER	1000 mm
MAX SOLIDS SIZE	125 mm Diameter
HOSE PORT	1 1/2" NPT
SUCTION FLANGE	n/a
DISCHARGE PORT	12" NPT F
POWER SOURCE	HT100D, HT150D or HT200D
PUMP CASING	Ductile Iron/Stainless Steel
IMPELLER	Ductile Iron
WEAR RING &/OR PLATE	Ductile Iron
SHAFT	17-4 PH Stainless Steel
SHAFT SEAL - STANDARD	Silicon Carbide
ALTERNATIVE SEAL	Refer to SPP
ELASTOMERS - STANDARD	Buna (N)
HYDRAULIC OIL	214-320 s.s.u. @ 64 Deg. C
INPUT FLOW	340 l/m Maximum
OPERATING PRESSURE	172 bar Maximum