

DEWATERING

HYDRAFLOW DATA SHEET

S8T 200mm Hydraulic Submersible Vortex Flow Pump

The SPP HYDRAFLOW S8T Hydraulic Drive Submersible Pump is a vortex flow pump designed to provide reliable high volume pumping on jobs ranging from wastewater to sewage to sludge and debris laden applications. Its ability to pass large semi-solids allows more shear sensitive materials to be pumped with less degradation.

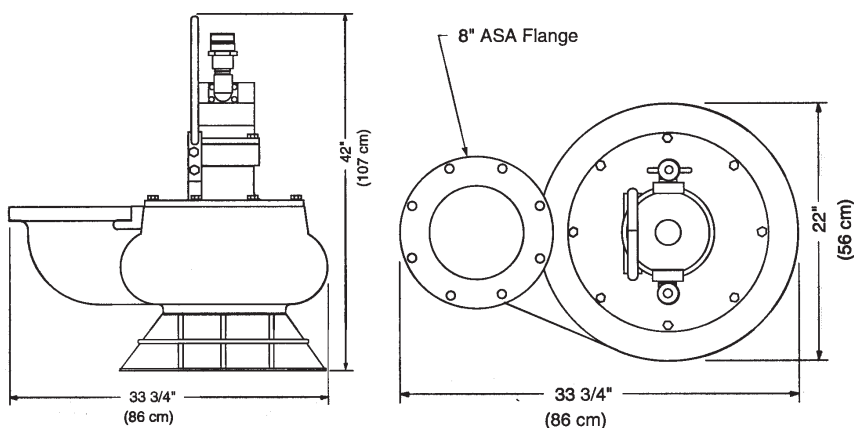

DESIGN FEATURES

- Recessed vortex impeller will pass 170mm semi-solids.
- Compact will fit through a 86mm opening.
- Oil lubricated seals - pump can run dry.
- Variable speed hydraulic motor drive.
- Wide range of performance.
- Can be bolted directed into a pipeline.
- Safe hydraulic drive can be used where electric power or hazardous or impractical
- Operates with our HT100D or HT150D Hydraulic Power Units or any open centre power source with output flows to 265 l/m.

DEWATERING

HYDRAFLOW DATA SHEET

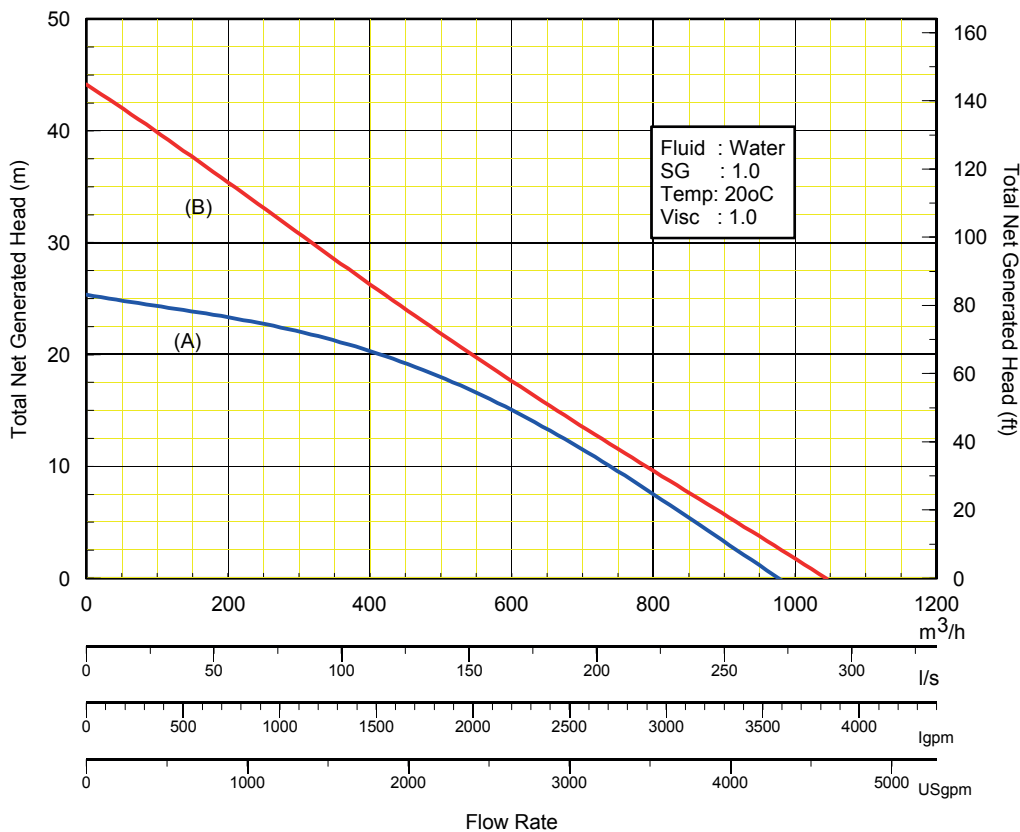

Hydraulic Input: (A) * 204 l/m @ 193 bar
(B) ** 265 l/m @ 193 bar
* Typical performance with HT100D
** Typical performance with HT150D

HYDRAULIC SUBMERSIBLE PUMP

PUMP TYPE	S8T
BRANCH SIZES	Suction: 200mm x Disch: 200mm
IMPELLER	Vortex
SOLIDS HANDLING	170mm diameter
HYDRAULIC MOTOR	Gear
INPUT - HYDRAULIC FLOW	265 l/m
INPUT - HYDRAULIC PRESSURE	193 bar
HYDRAULIC OIL	ISO 46
HYDRAULIC OIL TEMPERATURE	Max 140°F

PUMP SPECIFICATIONS

FLOW RATE	1050 m³/h Maximum
DISCHARGE HEAD	43 m Maximum
WEIGHT	263 kg
HEIGHT	1070 mm
MAX DIAMETER	860 mm
MAX SOLIDS SIZE	170 mm Diameter
HOSE PORT	1 1/4 & 1 1/2" NPT
SUCTION FLANGE	8" 125# ASA Flange
DISCHARGE PORT	8" 125# ASA Flange
POWER SOURCE	HT100D or HT150D
PUMP CASING	Ductile Iron
IMPELLER	Ductile Iron
WEAR RING &/OR PLATE	ASTM 36 Steel
SHAFT	17-4 PH Stainless Steel
SHAFT SEAL - STANDARD	Carbon Ceramic
ALTERNATIVE SEAL	Silicon Carbide
ELASTOMERS - STANDARD	Buna (N)
HYDRAULIC OIL	214-320 s.s.u. @ 64 Deg. C
INPUT FLOW	265 l/m Maximum
OPERATING PRESSURE	193 bar Maximum